

- Our course notes are now broken into 3 parts on OneDrive:
 - Part 1 - Electrostatics and DC Circuits:
https://tamucc-my.sharepoint.com/:o/g/personal/jeffery_spirko_tamucc_edu/EhkLjvTU1_pOkB5OmwRTR4lBMn97BZRqrl-ORgvyty7Zg
 - Part 2 - Magnetism and AC Circuits:
https://tamucc-my.sharepoint.com/:o/g/personal/jeffery_spirko_tamucc_edu/EuR1xpOWEK5LqEaOjXrgoQkqBZ7sy3B5pL6QA4wIUziVxQ
 - Part 3 - Oscillations, Waves, and Light:
https://tamucc-my.sharepoint.com/:o/g/personal/jeffery_spirko_tamucc_edu/EnXylWa4gm5FhPXWNb-bb4kB_7YX7TQsxRdh7HcSKATncg
- Our course notes are also periodically exported to PDF in:
<http://faculty.tamucc.edu/jspirko/Phys1402/>
- Professor: Dr. Jeff Spirko, jeffery.spirko@tamucc.edu, NRC-1111 (inside NRC-1100 suite)
- Office Hours: See Live Calendar <http://faculty.tamucc.edu/jspirko/calendar.html>
- Course Web Folder: <http://faculty.tamucc.edu/jspirko/Phys1402/> - Lecture Notes, Web Links
- Course YouTube Playlist: [Phys1402-Fall18](#)
- SI Info: [TBD]
- Sessions: [TBD]
- Office Hour: [TBD]
- Lab Web Folder: <http://physlab.tamucc.edu/> - Lab Policies, Practice Exercises, Lab Instructions, Auxiliary Files
- Textbook: Serway/Vuille, College Physics, 11th Edition (electronic version in WebAssign).
- Homework: Will appear on WebAssign.
- Lab Reports: Due 1 week after the lab, by midnight. Submit in the Lab Reports area in the Course Menu.

Why do we study E&M?

- Our society is electric
 - Energy: Heat, Light, Movement, Cooking
 - Information: Communication, Storage, Processing
- Fundamentals behind Light and Radio Waves.
- Basis of Chemistry (along with quantum mechanics)
- Used to measure and control experiments and processes.
- Math and Learning Practice.

- All matter is made of atoms.
- Atoms are made of Protons, Neutrons, and Electrons.

The protons and neutrons are gathered in the nucleus.
The electrons "orbit" around it in a cloud.
Each proton always has the same positive charge.
Each electron always has the same negative charge.
Charge is a measurement of "how electric" something is.
Positive and negative charges cancel via addition.
Protons and electrons cannot be created or destroyed.
This means charge cannot be created or destroyed.

$$q_p = +e$$
$$q_e = -e$$
$$e = 1.6 \times 10^{-19} \text{ C}$$

elementary charge

Generally, the protons stay in place. They are attached to the nuclei. A few forms of proton movement:

- Nuclear reactions, particle physics beams.
 - Chemical reactions.
 - Material flow.
- } In a battery.

Otherwise, it's just the electrons that flow. This is the flow of electricity in wires.

Electric Force

Monday, August 27, 2018 2:54 PM

Most basic interaction of Physics I: Force

The electric force is called the Coulomb Force.

The easiest case is two small, far-apart charges.

$$e = 1.6 \times 10^{-19} \text{ C}$$

Ex: Opposite Charges Attract

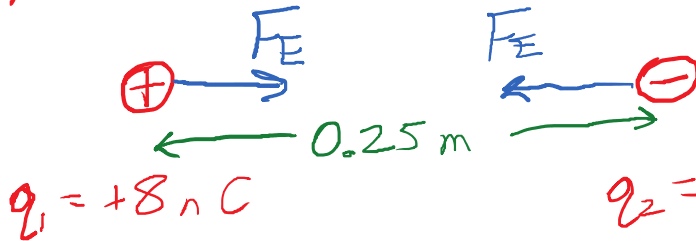

$$F_E = k \frac{|q_1| |q_2|}{r^2}$$

$$k = 9 \times 10^9 \text{ Nm}^2/\text{C}^2$$

r = center-to-center distance

$$F_E = \frac{(9 \times 10^9 \text{ Nm}^2/\text{C}^2)(8 \times 10^{-9} \text{ C})(5 \times 10^{-9} \text{ C})}{(0.25 \text{ m})^2} = 5.76 \times 10^{-6} \text{ N}$$
$$= 5.76 \mu\text{N}$$

Charged Objects

Monday, August 27, 2018 3:06 PM

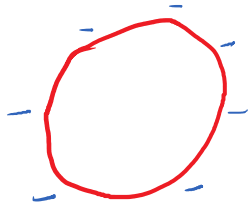

Metal Ball

w/ extra electrons

Metal is a conductor, which means the electrons are free to roam around where they want. Any balanced charges spread out throughout the metal. Any extra charges repel and go to the edges. The middle (called the "bulk") is neutral.

What if I have two charged metal spheres and bring them into contact?

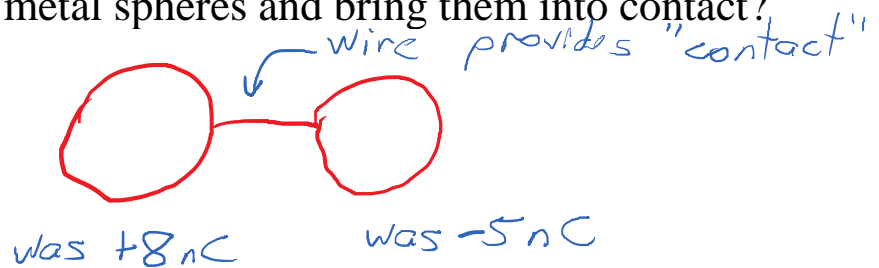

Both charges end up spreading out to both sides of the system. If the objects are symmetric, so are the charges.

$$Q_T = +8 - 5 = +3 \text{ nC}$$

$$\begin{aligned} \text{new } q_1 &= +1.5 \text{ nC} \\ \text{new } q_2 &= +1.5 \text{ nC} \end{aligned}$$

The electrostatic force depends on:

- Charge magnitude: "how electric" the objects are.
- Charge types: Like charges repel; opposites attract.
- Distance: Closer objects experience more force.

Coulomb's Law

$$F_E = k \frac{|q_1| |q_2|}{r^2}$$

$$k = 9 \times 10^9 \frac{\text{Nm}^2}{\text{C}^2}$$

Restrictions/limitations: The charges must be "small" compared to the distance between them.

A "neutral" object has $q = 0$ which makes us think there should be no electric force, ever, on a neutral object. But, actual objects are still made of + and - charges. A "polarizable" object allows its electrons to stretch away from the nuclei just a little bit. This can cause an attraction to any charged object.

Charge Distributions

Wednesday, August 29, 2018 2:25 PM

Bunch of points:

+ - - +
- + + -

$$Q = q_1 + q_2 + \dots$$

Ex: A $+1 \text{ nC}$ charge has how many extra protons?

$$Q = q_1 + q_2 + \dots$$

$$Q = Ne$$

$$(1 \text{ nC}) = N(1.6 \times 10^{-19} \text{ C})$$

$$N = \frac{1 \times 10^{-9} \text{ C}}{1.6 \times 10^{-19} \text{ C}} = 6.25 \times 10^9$$

This is usually done by stealing 6.25×10^9 electrons, not by adding protons.

Surface Charges: Charge spread out on a surface.

$$\sigma = \frac{Q}{A}$$

↑
Surface Charge Density

Volume Charges: Charge spread out throughout a 3-D region.

$$\rho = \frac{Q}{V}$$

↑
Volume Charge Density

Electric Field

Wednesday, August 29, 2018 2:37 PM

How can we exert a particular force on a charge?

$$F = \frac{kq_1q_2}{r^2}$$

- Strong q_2 , far away
- Weak q_2 , nearby

$$F = \frac{kq_1q_2}{r_2^2} + \frac{kq_1q_3}{r_3^2}$$

- Multiple other charges.

We could rearrange this by dividing the q_1 over to the other side.

$$\frac{F}{q_1} = \underbrace{\left(\frac{kq_2}{r_2^2} + \frac{kq_3}{r_3^2} + \dots \right)}_{\text{Environment}} = E$$

The "test charge" q_1 doesn't care how E is created. All that matters in determining the force is q_1 and E .

Coulomb Force: $\vec{F} = q_0 \vec{E}$

↑
Electric Field of All other charges.

The electric force is:

- In the same direction as \vec{E} for a \oplus charge.
- Opposite to \vec{E} for a \ominus charge.

The charges creating E are called "source charges".

The electric field E exerts forces on other "test charges".

The electric field acts as a conceptual middle-man between the source and test charges. But it exists whether there are test charges or not.

E-Field of a point charge

Wednesday, August 29, 2018 2:55 PM

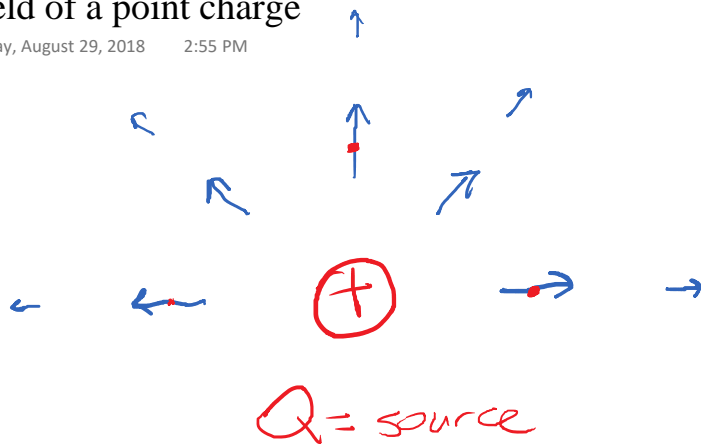

Imagine a $\oplus q_0$ test charge at each dot, where would the force point?

The electric field of a + source points away from the source.

$$E = \frac{F}{q_0} = \frac{1}{q_0} \left(k \frac{q_0 Q}{r^2} \right) = \frac{kQ}{r^2}$$

Test Charge $\rightarrow q_0$

If there are multiple sources, their electric fields add as vectors.

Where is $E=0$?



+2 nC

+2 nC

Dots are candidates where fields are opposite.

$$E_1 = \frac{k(2 \text{ nC})}{r_1^2}$$

$$E_2 = \frac{k(2 \text{ nC})}{r_2^2}$$

Since the charges are equal, the distances must be equal, and the point we are looking for is in the middle.

New Ex:



+1 nC

+4 nC

Where is $E=0$?

Intuitively, our point must be closer to the weaker charge.

$$E_1 = E_2$$

$$\frac{kq_1}{r_1^2} = \frac{kq_2}{r_2^2}$$

$$\frac{1}{r_1^2} = \frac{4}{r_2^2}$$

$$r_2^2 = 4r_1^2$$

$$r_2 = 2r_1$$

Lec 3, Labor Day, No Class

Monday, October 15, 2018 8:24 PM

First, let's remember gravity.

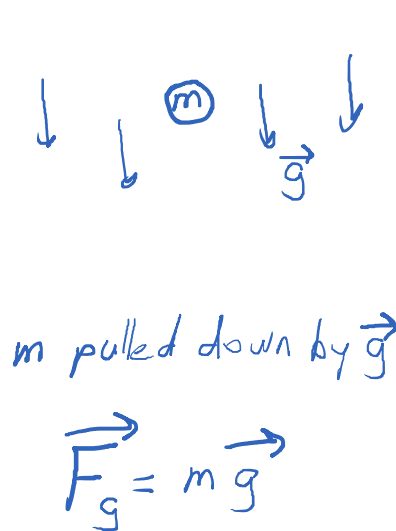
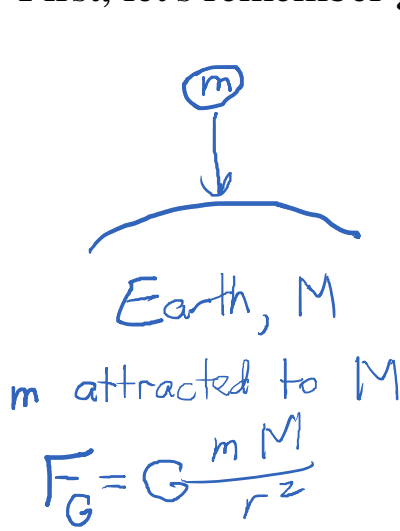

• High mgh
 • Low mgh
 m attracted to low mgh.

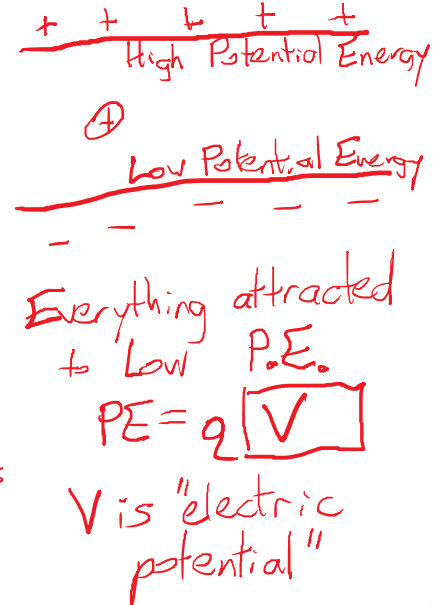
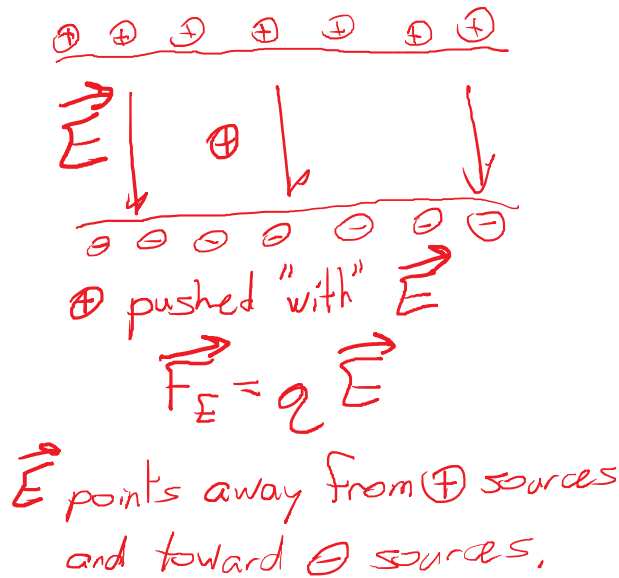
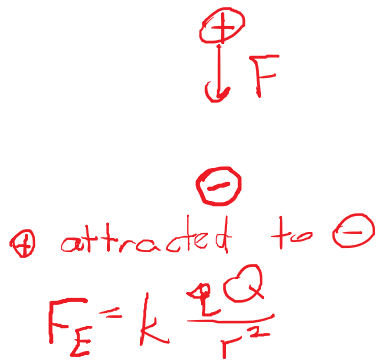

What is electric potential?

- Potential energy per unit test charge
- Positive test charges attracted toward lower (less positive or more negative) potential.
- Positive potentials generated by positive source charges. Negative potential generated by negative sources.
- We don't really know where "zero" is. Earth is generally at the same potential, so we use that.

What about negative test charges?

Sources \rightarrow Fields \rightarrow Test
 Q create affect q

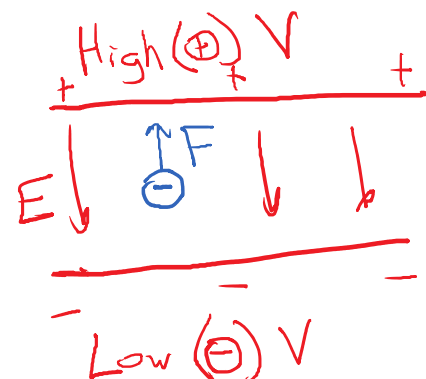

that.

What about negative test charges?

- The sources don't change. The fields don't change. (E = electric field, V = potential field)
- The negative test charges are attracted the other way.

$$\begin{array}{c} \text{Low } (\ominus) V \\ PE = q V \\ \begin{array}{cc} \uparrow & \uparrow \\ \text{opposite to } V & \text{negative} \end{array} \end{array}$$

Calculating Potentials

Wednesday, September 5, 2018 2:36 PM

Point Source

(FQ)

$$V = \frac{kQ}{r}$$

Different From $E = \frac{kQ}{r^2}$:

- Different denominator
- V not a vector

Capacitor

Two parallel metal plates, charged opposite but with equal magnitudes.

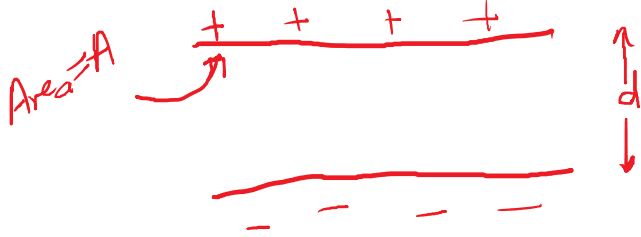

Lower d = Easier to gather charges.
 Bigger A = More room to spread out.

$$\text{Capacitance: } C = \frac{\kappa \epsilon_0 A}{d}$$

$\kappa = \text{kappa} = \text{dielectric constant} = 1 \text{ or larger}$
 $\epsilon_0 = 8.85 \times 10^{-12} \frac{\text{C}^2}{\text{Nm}^2}$ ← coulombs

$C = \text{capacitance in farads (F)}$

Typical: $C = 25 \mu\text{F} = 25 \times 10^{-6} \text{ F}$

Capacitance tells us how much voltage (V) it takes to put a certain amount of charge (Q) inside.

$$Q = CV$$

Ex: Hook $25 \mu\text{F}$ capacitor to a 3 V battery.
 $V_B = 3 \text{ V}$ ↑ volts = unit of V

$$Q = (25 \times 10^{-6} \text{ F})(3.0 \text{ V})$$

$$= 75 \times 10^{-6} \text{ C}$$

$$Q = 75 \mu\text{C}$$

Other things a Capacitor does

Wednesday, September 5, 2018 2:56 PM

Store Energy $Q = CV$
 $Energy = \frac{1}{2} QV = \frac{1}{2} CV^2$

Recall, for a test charge $PE = qV$

Ex: $Energy = \frac{1}{2} (25 \times 10^{-6} F) (3.0 V)^2$
 $= 112.5 \times 10^{-6} J = 112.5 \mu J$

Generate E-Field $E = \frac{V}{d}$

Ex: $25 \mu F$ with $d = 20 \text{ nm}$, $3.0 V$
 $E = \frac{3.0 V}{20 \times 10^{-9} m} = 150,000,000 \text{ V/m}$
 $= 1.5 \times 10^8 \text{ V/m} = 150 \frac{MV}{m}$

Note: E-field is force per unit test charge, in N/C.

Now, E-field can also be measured in V/m.

These are the exact same, equivalent units.

Electric potential is like:

- Height
- Pressure

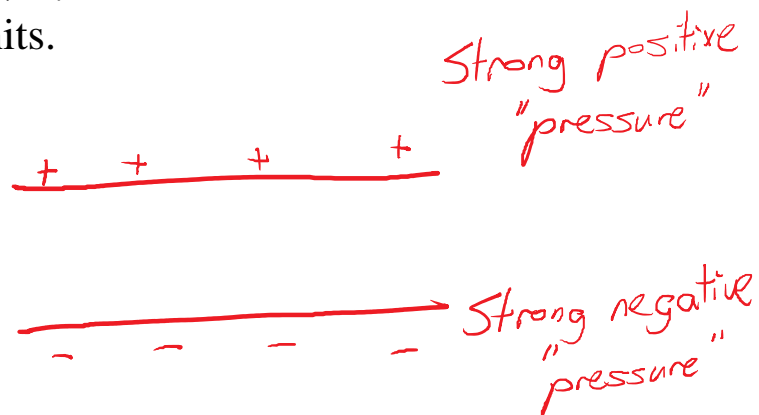

Electrostatics

High Voltages (usually)

"Dead-end" containers

Charge builds up.

Tiny amounts of q .

DC Circuits

Low Voltages

Continuous paths

No buildup, just flow.

Lots of flow, but no excess in any one place.

Voltage: Motivation for current to flow. Need a voltage source for any current to flow.

Current: Rate of flow of charges.

$$I = \frac{\Delta Q}{\Delta t}$$

Current \nearrow \nwarrow Amount of moving charge
 \nwarrow Time elapsed

How do we measure current?

- Current meter called an ammeter
- Intercept the flow of current and make it go through the meter.
- We want the measured value to be the same as what the current was before we intercepted it. The ammeter must allow current to flow easily.

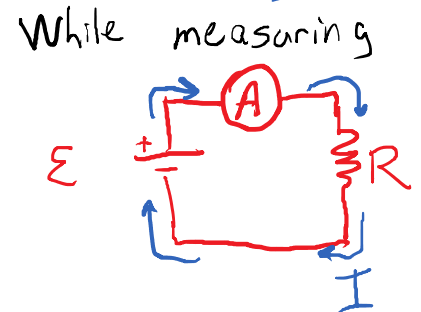
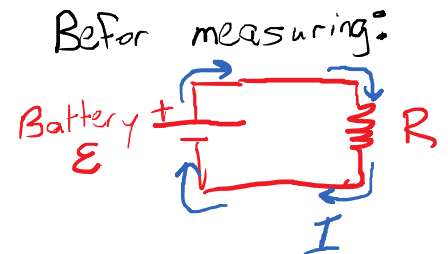

Electric Rate: \$0.12 / kWh

$$\text{Power} = \frac{\Delta \text{Energy}}{\Delta t} \Rightarrow \Delta \text{Energy} = P \Delta t$$

SI Units: $1 \text{ J} = (1 \text{ W})(1 \text{ s})$

On invoice: $1 \text{ kWh} = (1000 \text{ W})(3600 \text{ s}) = 3600000 \text{ W}\cdot\text{s}$
 $= 3.6 \times 10^6 \text{ J}$

What if we leave a 1 W device operating for a whole month?

$$\text{Energy} = P \Delta t = (1.0 \text{ W})(30 \text{ days}) \left(\frac{24 \text{ hours}}{1 \text{ day}} \right) \left(\frac{1 \text{ kW}}{1000 \text{ W}} \right)$$

$$= 0.72 \text{ kW}$$

$$\text{Cost} = (0.72 \text{ kW}) \left(\frac{\$0.12}{\text{kW}} \right) = \$0.086$$

$$\text{Cost} = (\text{Amount}) (\text{Rate})$$

Let's say I leave the porch light on all of the time.

| | | |
|---------------|------|--------------------|
| Incandescent: | 75 W | ~ \$6.50 per month |
| LED | 10 W | ~ \$0.86 per month |

Measuring Voltage

Monday, September 10, 2018 2:49 PM

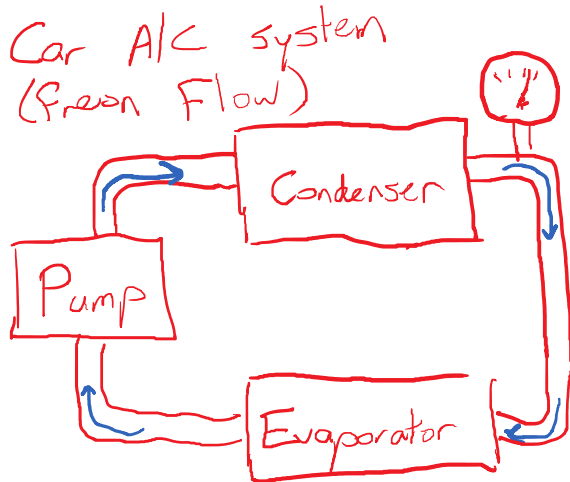

Pressure gauge is a "dead-end" path.

It measures the pressure difference between the freon pipe and the atmosphere.

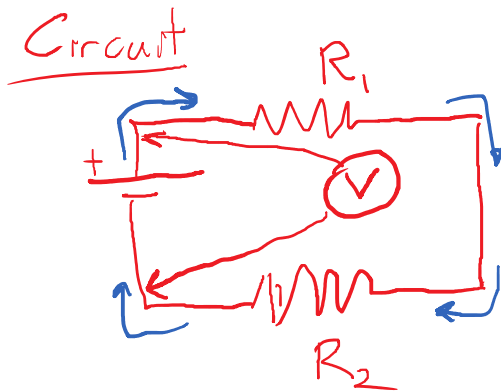

- Just like the pressure gauge, the voltmeter is a dead-end path. No current flows through it.
- The voltmeter needs to measure a voltage difference. The voltmeter is connected to 2 points in a circuit.
- The voltmeter to the left is connected "across the battery".
- The current is unaffected by the voltmeter.

Measuring Resistance and Power

Monday, September 10, 2018 3:00 PM

Defined by $V = I R$

- Place a known V across a resistor.
- Measure the current I that flows.
- Divide to calculate the resistance.

An ohmmeter does all of these things for us.

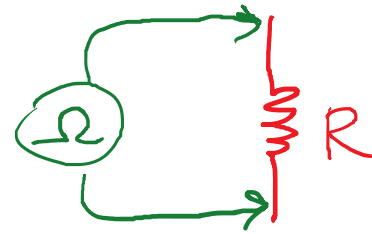

Note that there must not be another voltage source in the circuit. That would confuse the ohmmeter and yield garbage results (at best) or cause damage (at worst).

How about measuring power?

Defined by $P = V I$

Must measure both voltage (V) and current (I) while the circuit is operating as designed (i.e. with another voltage source).

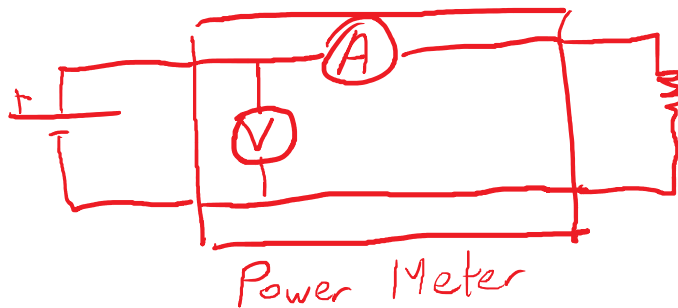

Lec 6 - Series and Parallel - Series Circuit Components

Wednesday, September 12, 2018 1:54 PM

Simple Circuit:

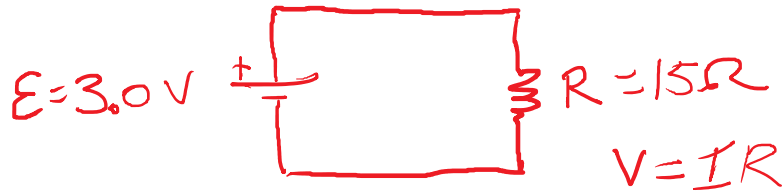

Current: $I = \frac{V}{R} = \frac{3.0V}{15\Omega} = 0.2A$

When we measure current, we place the meter **in series** so that the current must go through the meter.

When two components are in series, they have the same current. Recognize this by a connection between them with no branches.

Series Resistors

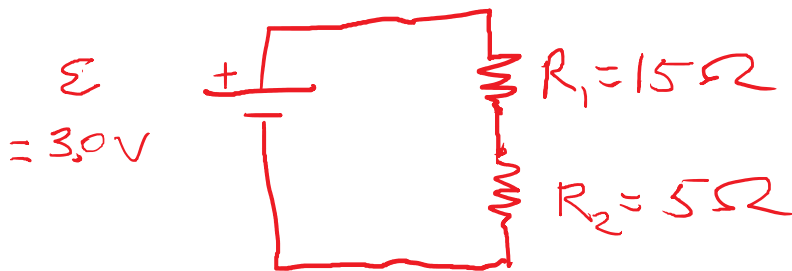

R_1 and R_2 have the same current.

$I_1 = I_2$ (In series)

Voltage is energy per charge.

$P_{\text{batt}} = \epsilon I$
Gen by batt.

$P_1 = I V_1$
Used by R_1

$P_2 = I V_2$
Used by R_2

$P_{\text{batt}} = P_1 + P_2$
 $\epsilon I = V_1 I + V_2 I$
 $\epsilon = V_1 + V_2$

Voltages add in series.

$R_1 = 15\Omega$

Measured $V_1 = 2.25V$

$R_2 = 5\Omega$

Measured $V_2 = 0.75V$

Notes:

$V_1 + V_2 = 3.0V \checkmark$
 $V_1 = 2.25 \quad 15\Omega \checkmark$

$$R_2 = 5\Omega \quad \text{Measured } V_2 = 0.75\text{V}$$

$$V_1 + V_2 = 3.0\text{V}$$

$$\frac{V_1}{V_2} = \frac{2.25}{0.75} = 3 = \frac{15\Omega}{5\Omega} \checkmark$$

$$I = \frac{V_1}{R_1} = \frac{2.25\text{V}}{15\Omega} = 0.15\text{A}$$

In series, the bigger R gets a larger share of the voltage.

From the battery's perspective:

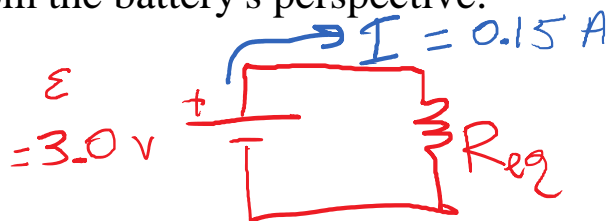

$$V = I R_{eq}$$

$$(3.0\text{V}) = (0.15\text{A}) R_{eq}$$

$$\frac{3.0\text{V}}{0.15\text{A}} = 20\Omega = R_{eq}$$

Series resistors act like a single equivalent resistance, where:

$$R_{eq} = (R_1 + R_2 + \dots)$$

Important example: Internal Resistance of a Battery



$$\epsilon = IR_i + IR_{int}$$

$$\epsilon = V_{\text{terminal}} + IR_{int}$$

Parallel Circuits

Wednesday, September 12, 2018 2:43 PM

Parallel Resistors

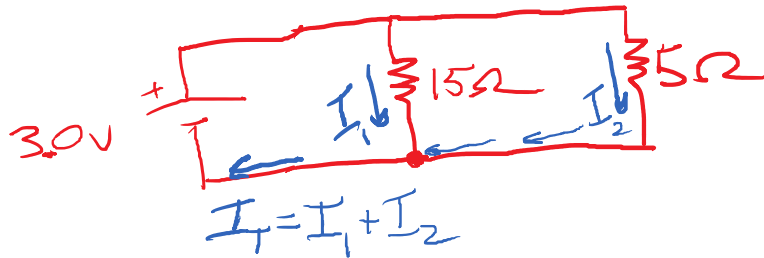

• Parallel means attached at both ends.

• Current adds in parallel

• Voltages are the same in parallel.

Power:

$$\mathcal{E} I_T = V_1 I_1 + V_2 I_2$$

Only way for this to work is:

$$\mathcal{E} = V_1 = V_2$$

Parallel Equivalent Resistance

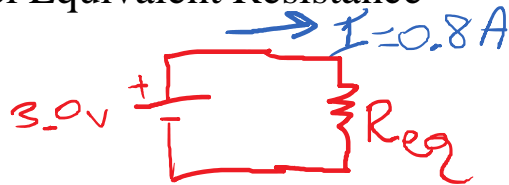

$$I_1 = \frac{3.0}{15} = 0.2 \text{ A}$$

$$I_2 = \frac{3.0}{5} = 0.6 \text{ A}$$

$$I_T = I_1 + I_2 = 0.8 \text{ A}$$

$$R_{eq} = \frac{3.0 \text{ V}}{0.8 \text{ A}} = 3.75 \Omega$$

Direct calculation?

$$I_T = I_1 + I_2$$

$$\frac{\mathcal{E}}{R_{eq}} = \frac{\mathcal{E}}{R_1} + \frac{\mathcal{E}}{R_2}$$

$$\frac{1}{R_{eq}} = \frac{1}{R_1} + \frac{1}{R_2} + \dots$$

$$R_{eq}^{-1} = R_1^{-1} + R_2^{-1}$$

$$R_{eq} = \left(\frac{1}{R_1} + \frac{1}{R_2} + \dots \right)^{-1}$$

$$(1/15 + 1/5)^{-1} = 3.75$$

Easy-to-do Calculations:

$R_1 = R_2$ In Series: $R_{eq} = R_1 + R_1 = 2 R_1$

In Parallel: $n \text{ } (\perp \dots \perp)^{-1}$

I_n Parallel: $R_{eq} = \left(\frac{1}{R_1} + \frac{1}{R_1} \right)^{-1}$
 $= \left(\frac{2}{R_1} \right)^{-1} = \frac{R_1}{2}$

Combination Circuits

Wednesday, September 12, 2018 2:59 PM



| | V | I | R |
|----------|------|-------|------|
| R_1 | 7.5V | 1.5A | 5Ω • |
| R_2 | 4.5V | 1.125 | 4Ω |
| R_3 | 4.5V | 0.375 | 12Ω |
| R_4 | 12V | 1.5A | 8Ω • |
| <hr/> | | | |
| Tot | 24V | 1.5A | 16Ω |
| R_{23} | 4.5V | 1.5A | 3Ω • |

$R_2 \parallel R_3$

$$R_{23} = \left(\frac{1}{4} + \frac{1}{12} \right)^{-1} = 3\Omega$$



$$I = \frac{24V}{16\Omega} = 1.5A = I_1 = I_{23} = I_4$$

For a looping path
 $\sum \mathcal{E} = \sum V_{used}$

How could we add up voltages to get 24 V?

We could add $V_1 + V_2 + V_4 = 7.5 + 4.5 + 12 = 24$

Or we could: $V_1 + V_3 + V_4 = 7.5 + 4.5 + 12 = 24$

Lec 7 - More Circuits - Kirchoff's Laws

Monday, September 17, 2018 1:56 PM

• Current: Total in = Total out



$$(6.0 A) = (4.0 A) + I_3$$

$$2.0 A = I_3$$

Consequences: In series, each current is the same.



$$I_1 = I_2$$

In parallel, currents add.

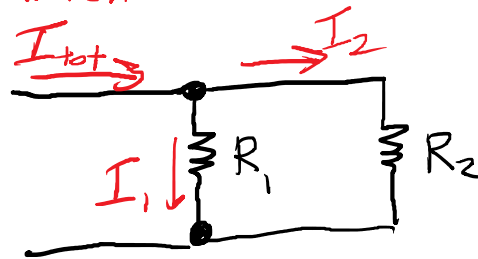

$$I_{Tot} = I_1 + I_2$$

• Voltage Law: If you add up the voltages in any loop, the total is zero.

$$\text{Total } \Delta V = 0$$

$$\text{Total Source } \Delta V = \text{Total Used } \Delta V$$

$$\sum \mathcal{E} = \sum (IR)$$

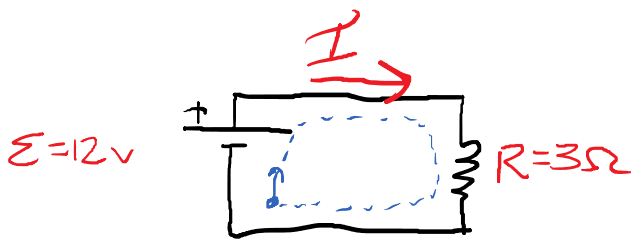

$$12v = I(3\Omega)$$

$$\frac{12}{3} = 4.0A = I$$

Series:

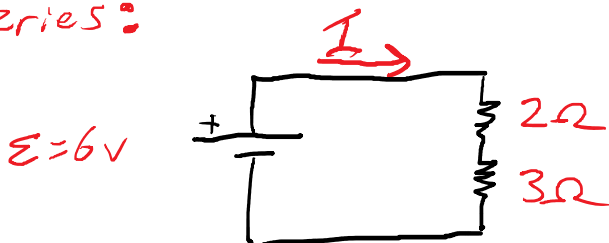

$$6v = I(2\Omega) + I(3\Omega)$$

Series voltages Add

$$\frac{6}{2} = (1.2A) = I \quad \leftarrow \quad 6v = I(2\Omega + 3\Omega)$$

Series R's Add

Parallel:

$$\mathcal{E} = 3\text{V}$$

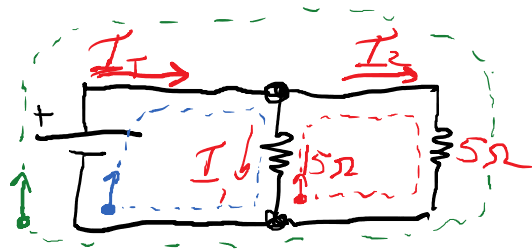

$$I_T = I_1 + I_2$$

$$\bullet 3\text{V} = I_1(15\Omega)$$

$$\bullet 3\text{V} = I_2(5\Omega)$$

What about the "right loop"?

$$\bullet 0 = I_1(15\Omega) + I_2(5\Omega)$$

(Broken!)

This only "works" if one is negative.

Rule to fix this: If your loop goes "backwards" across a resistor, add a minus sign.

$$0 = -I_1(15\Omega) + I_2(5\Omega)$$

(Fixed)

$$\text{Algebra} \rightarrow I_1(15\Omega) = I_2(5\Omega)$$

$$\text{Gives parallel voltage rule: } V_1 = V_2$$

Application of Kirchoff's Laws

Monday, September 17, 2018 2:37 PM

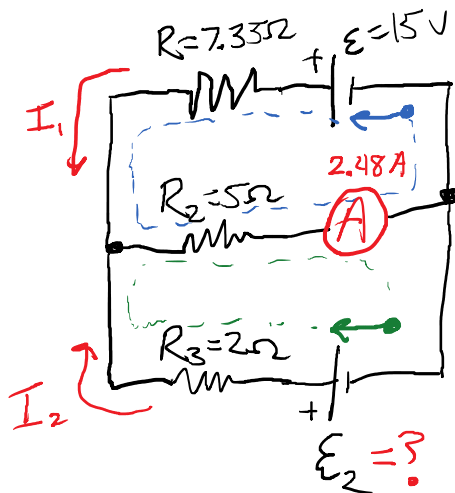

Current Law: $I_1 + I_2 = (2.48A)$

Bottom Loop: $E_2 = I_2(2\Omega) + (2.48A)(5\Omega)$

Top Loop: $(+15V) = I_1(7.35\Omega) + (2.48A)(5\Omega)$

Algebra: $15 = 7.35I_1 + 12.4$

$2.6 = 7.35I_1$

$I_1 = \frac{2.6}{7.35} = 0.354A$

$0.354 + I_2 = 2.48 \rightarrow I_2 = 2.126A$

$E_2 = (2.126)(2\Omega) + (2.48)(5\Omega) = 16.7V$

Outer Loop Kirchoff's Voltage Law:

Start @ top-right, counter-cw $(15V) - (16.7V) = I_1(7.35) - I_2(2)$

We went backwards across EMF2.

$15 - 16.7 = 2.6 - 4.252$

$-1.7 = -1.65 \checkmark$ (Roundoff Error)

RC Circuits

Monday, September 17, 2018 3:00 PM

A capacitor can store voltage and energy, and provide current, much like a battery.

Battery Circuit

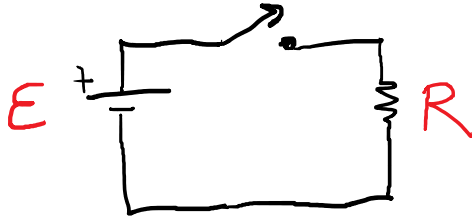

$$V_{\text{batt}} = \mathcal{E} = \text{const}$$

Capacitor Circuit

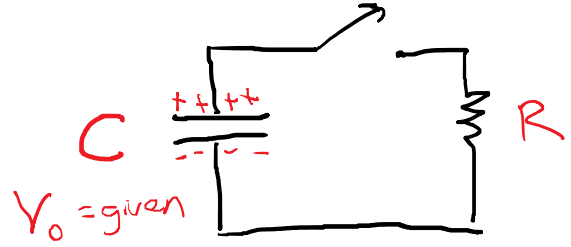

$$Q = CV$$

$$V_c = \frac{Q}{C}$$

$C = \text{capacitance (F)}$
 $Q = \text{charge (C)}$

If $V_{\text{batt}} = V_c$, these circuits behave the same ... at first. But the battery can maintain its voltage continuously. The capacitor starts becoming "drained" immediately. Since the capacitor voltage is proportional to its charge, both start decreasing immediately. The resistor will feel the lower voltage and draw less current.

The voltage decreases exponentially.

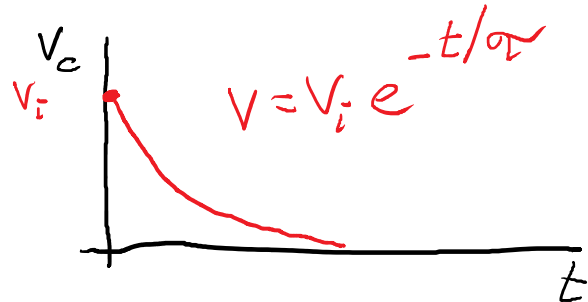

Lec 8 - Capacitors and RC Circuits

Homework Questions

Wednesday, September 19, 2018 1:56 PM

Consider the circuit shown below. (Assume $\mathcal{E} = 9.00 \text{ V}$, $R_1 = 1.50 \Omega$, $R_2 = 4.30 \Omega$, $R_3 = 5.50 \Omega$, and $R_4 = 11.0 \Omega$.)



This circuit is easier.

$$V_2 = V_3 = V_4 = V_{234}$$

$$I_2 + I_3 + I_4 = I_{234} \quad (\text{Not usually easy to apply.})$$

A typical hair dryer consumes $1.60 \times 10^3 \text{ W}$ of electrical power. If the hair dryer runs for 14.4 minutes, determine the following.

- (a) the amount of energy consumed
- (c) the cost of this energy, assuming the electrical power company charges \$0.120 per kWh

$$P = \frac{\Delta \text{Energy}}{\Delta t} \quad \Delta \text{Energy} = P \Delta t$$

$$(\text{Total Cost}) = (\text{Unit Cost})(\text{Amount})$$

$$\begin{aligned} 1 \text{ J} &= (1 \text{ W})(1 \text{ s}) \\ 1 \text{ kWh} &= (1 \text{ kW})(1 \text{ hour}) \\ &= (1000 \text{ W})(3600 \text{ s}) \\ &= 3.6 \times 10^6 \text{ J} \end{aligned}$$

Capacitors in DC Circuits

Wednesday, September 19, 2018 2:21 PM

- All charges generate voltage. $V = \frac{kq}{r}$
- Isolated charges make huge V w/ little q .
- V is
 - Energy per unit charge
 - Difficulty of moving more charges.
- Capacitors make it easy to gather lots of q w/ little V .



$$Q = CV$$

Q = charge on one plate
in coulombs (C)

C = capacitance in farads (F)

V = voltage in volts (V)

Inside, 2 things happen:

$$\text{Elec Field} = E = \frac{V}{d} \leftarrow \text{distance between plates}$$

$$\text{Energy} = \frac{1}{2} \left(\frac{\text{Energy}}{\text{Charge}} \right) (\text{Charge}) = \frac{1}{2} VQ$$

RC Circuits - The process of charging and discharging.

Wednesday, September 19, 2018 2:36 PM

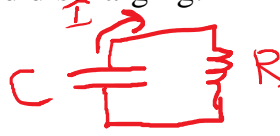

Discharging

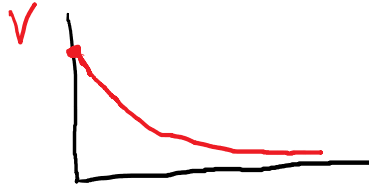
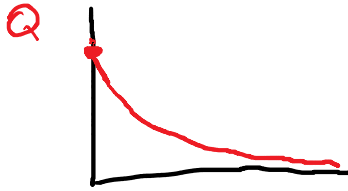

All are exponential decay.

$$Q = Q_0 e^{-t/\tau}$$

$$V = V_0 e^{-t/\tau}$$

$$I = I_0 e^{-t/\tau}$$

For discharging, $\exp(-t/\tau)$ is the fraction of charge remaining.

| t/τ | $e^{-t/\tau}$ | Percentage |
|----------|---------------|------------|
| 0 | 1.0 | 100% |
| 1.0 | 0.37 | 37% |
| 2.0 | 0.14 | 14% |
| 3.0 | | 5% |
| 4.0 | | 2% |
| 5.0 | | 1% |

$(0.37)(0.37)$ (indicated by a bracket between 1.0 and 2.0)
 After 5τ , we're 99% done.

How much time does it take to get to 50% of the original charge?

$$Q = (0.5) Q_0$$

$$Q = Q_0 e^{-t/\tau}$$

$$0.5 = e^{-t/\tau}$$

$$\ln(0.5) = \frac{-t}{\tau}$$

$$-0.693 = -t/\tau$$

$$0.693\tau = t$$

ln x finds y value
to solve $x = e^y$
 $\ln x = y$

The time constant (τ) depends on the

resistance and capacitance.

- Bigger capacitors take more time to drain.
- Bigger resistors make the draining slower.

$$\tau = RC$$

Charging

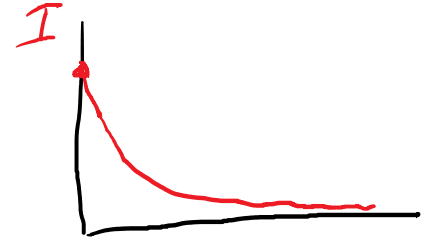
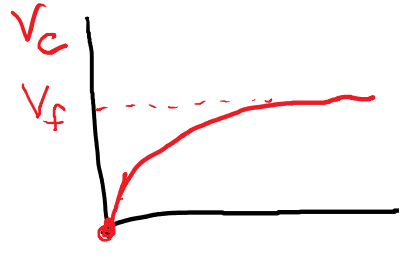
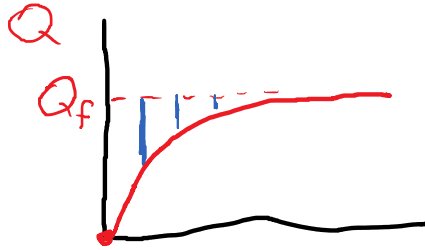

$$Q_f - Q = Q_f e^{-t/\tau}$$
$$Q = Q_f (1 - e^{-t/\tau})$$

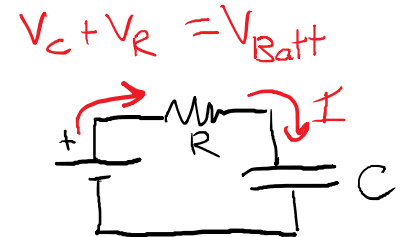
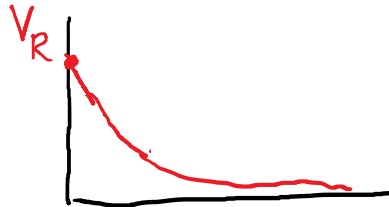

Exponentially approaching a final value.

It takes 5 time constants to be 99% complete.

$$\ln(0.01) = -4.605170185988091$$

$$\approx -5$$

Focus on understanding exponential decay (discharging) for the exam.

Test is Wed 9/26.

Covers Electrostatics and DC Circuits (including RC)

Chap 15-18, HW1 and HW2, Labs 1-4.

HW2-14: Combination Circuit

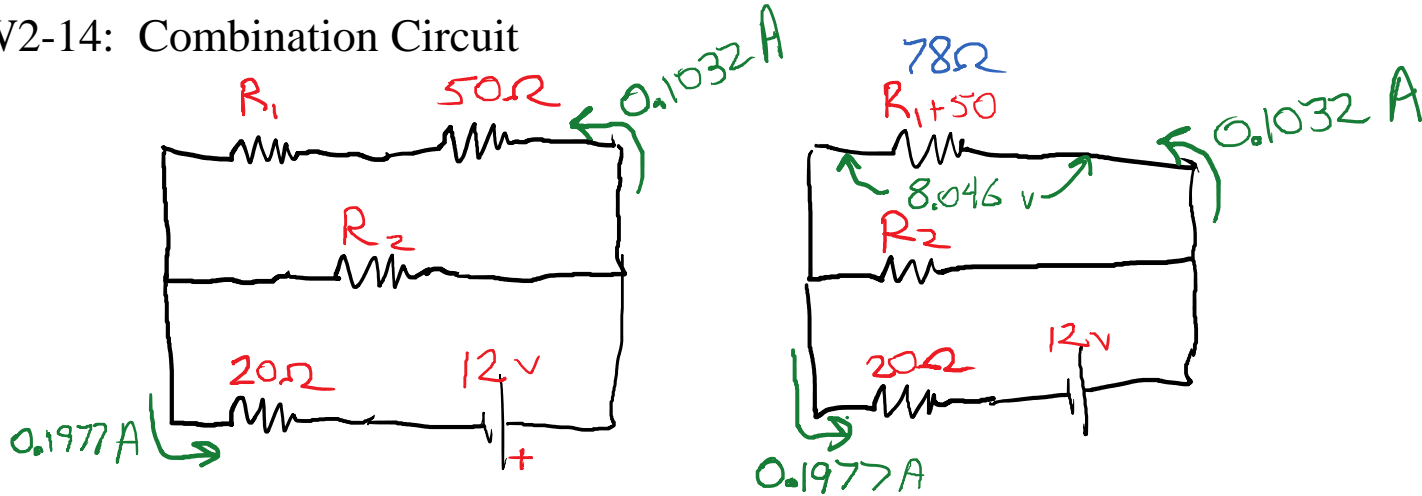

$$E_x = R_1 = 28\Omega$$

$$R_1 + 50 = 78\Omega$$

$$(R_1 + 50) \parallel R_2 = 40.7\Omega$$

$$R_2 = 85\Omega$$

$$(R_1 + 50) \parallel R_2 = \left(\frac{1}{78} + \frac{1}{85} \right)^{-1} = 40.7$$

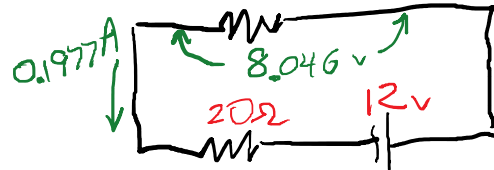

$$I = 12 / 60.7 = 0.1977$$

$$V_{40.7} = IR = (0.1977) * (40.7) = 8.0464$$

$$I_{(R1+50)} = V/R = 8.0464 / 78 = 0.1032$$

$$P_{50} = V * I = (IR) * I = I^2 * R = (0.1032)^2 * 50 = 0.5325 \text{ W}$$

Equivalent Circuits:

- Redraw, combining series or parallel resistors into an equivalent.
- Keep simplifying until a pure series or pure parallel circuit is found.
- Transfer values back up through the previous iterations.
 - Parts of the circuit that didn't change get the same currents and voltages.
 - Series equivalents have the same current as their components.
 - Parallel equivalents have the same voltage as their components.

Electric Field

- Generated by charges. Points away from + and toward -.
- Point charges make a diverging (or converging) field.

$$E = \frac{kQ}{R^2}$$

- Proportional to Q
- Weaker with distance

- Capacitors make a uniform field.

$$E = \frac{V}{d} = \frac{Q}{Cd} = \frac{Q}{\epsilon_0 A d}$$

- Proportional to Q

- Same strength everywhere inside capacitor.

$$C = \frac{\epsilon_0 A}{d}$$

$$Q = CV$$

$$\hookrightarrow V = \frac{Q}{C}$$

- Electric field causes forces on other charges.

$$\vec{F}_E = q\vec{E}$$

$q =$ "test charge"

- If the test charge is negative, F_E is opposite to E .
- We use test charges to measure E .

- Electric field is closely related to voltage.

$$E = \frac{-\Delta V}{\Delta x} = \frac{\text{Voltage Change}}{\text{Displacement}}$$

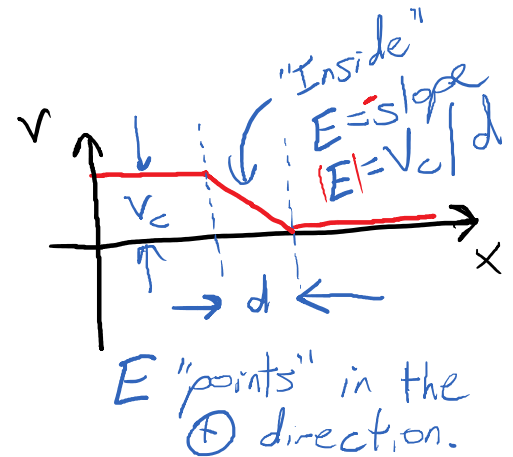

- Electric field points "downhill"

A 5 micro-F capacitor has 20 V across it. The capacitor's plate separation is 0.1 mm.

- Electric field inside?

$$E = \frac{V}{d} = \frac{20 \text{ V}}{0.1 \times 10^{-3} \text{ m}} = 200000 \text{ V/m}$$

- Force on a loose electron between plates? $F = qE = (1.6 \times 10^{-19} \text{ C})(200000 \text{ N/C})$

$$= 3.2 \times 10^{-14} \text{ N}$$

- Acceleration of loose electron between

$$= 3.2 \times 10^{-14} \text{ N}$$

- Acceleration of loose electron between plates? (no other forces)

$$F_{\text{net}} = ma = 3.2 \times 10^{-14} \text{ N}$$

$$a = \frac{F}{m} = \frac{3.2 \times 10^{-14} \text{ N}}{9.11 \times 10^{-31} \text{ kg}}$$

$$3.2 \times 10^{-14} / 9.11 \times 10^{-31} = 3.51 \times 10^{16} \text{ m/s}^2$$

- Speed if accelerated from one plate to the other? Release from rest

$$v_f^2 = v_i^2 + 2a\Delta x$$

$$v_f^2 = 2(3.51 \times 10^{16})(0.1 \times 10^{-3})$$

$$= 7 \times 10^{12} \text{ m}^2/\text{s}^2$$

$$2 * 3.51 \times 10^{16} * 0.1 \times 10^{-3} = 7.02 \times 10^{12}$$

- Kinetic energy of electron when it hits the other side?

$$KE = \frac{1}{2}mv^2 = \frac{1}{2}(9.11 \times 10^{-31})(7 \times 10^{12})$$

$$= 0.5 * 9.11 \times 10^{-31} * 7 \times 10^{12} = 3.2 \times 10^{-18} \text{ J}$$

- Energy per unit charge?

$$\frac{KE}{q} = \frac{3.2 \times 10^{-18}}{1.6 \times 10^{-19}} = 20 = \text{original voltage}$$

Where is the electric field zero?

Monday, September 24, 2018 3:08 PM

$$E = \frac{kQ}{R^2}$$

$$E_1 = \leftarrow$$

$$E_2 = \rightarrow$$

$$E_1 = \rightarrow$$

$$E_2 = \rightarrow$$

$$E_1 = \rightarrow$$

$$E_2 = \leftarrow$$

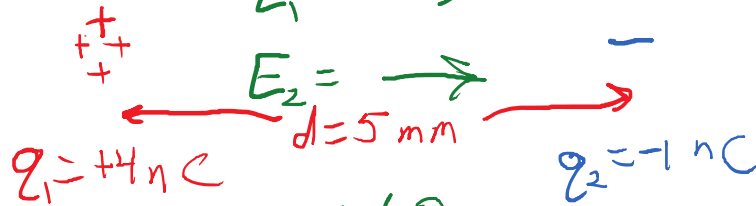

$$E_1 + E_2 \neq 0$$

q_1 stronger
 R_1 is more

$E_1 + E_2 = 0$?
check strengths

E_1 definitely stronger.

$$|E_1| = |E_2|$$

$$\frac{kq_1}{R_1^2} = \frac{kq_2}{R_2^2}$$

$$\frac{q_1}{q_2} = \left(\frac{R_1}{R_2}\right)^2$$

$$2 = \sqrt{\frac{4}{1}} = \sqrt{\frac{q_1}{q_2}} = \frac{R_1}{R_2} \quad R_1 = R_2 + (5 \text{ mm})$$

The logic is different if we're looking for a place where $V = 0$ (instead of $E = 0$).

Lec 10 - Exam 1 - No notes

Monday, October 15, 2018 9:04 PM